

Food Waste Disposer: Disperator 400 BAS for sink

Construction

The disposer grinds waste to a particle size that complies to MARPOL – regulations for discharging of food waste at sea.

No welding is required for installing into an existing sink unit. A screw joint attachment is fitted into a 90 mm drain hole in the bottom of the sink onto which the disposer is connected.

To suit drain connection the disposer with outlet can be turned and positioned in any direction

Use

Disperator food waste disposer Model 400 meets the requirements for handling small amounts of food waste in commercial kitchens and galleys.



Voltages: 220-240V single phase 50 or 60Hz

Accessories (included):

- Start / stop controller switch
- Removable food waste feeder and cutlery trap
- Jam release wrench

Options:

- Water trap
- Safety switch
- Solenoid valve for automatic flushing control

- EASY CLEANING
- ENERGY EFFICIENT
- SAFE OPERATION
- HIGH CAPACITY
- RECYCLABLE



06.15

Disposer Inlet Ø80mm
For sink drain Ø90mm

Screw joint assembly
No welding required

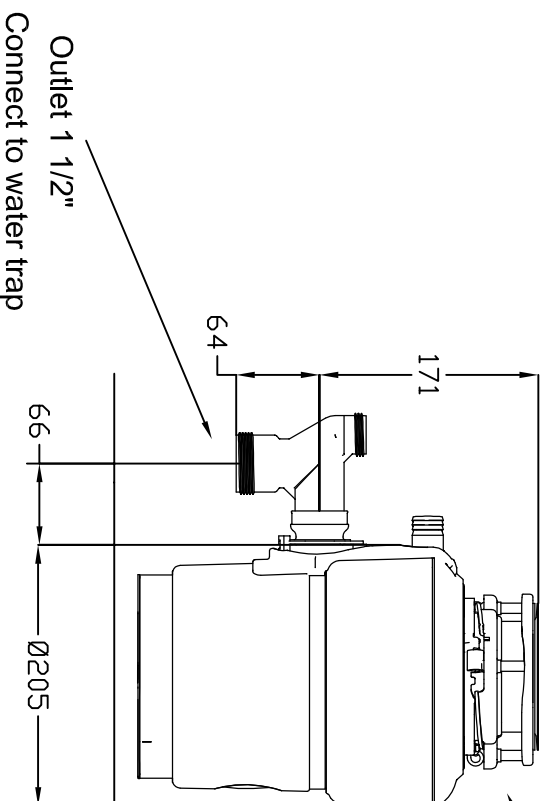

Side view

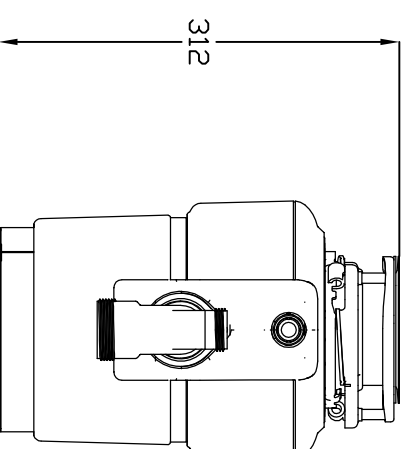

Front view

Cable 0,8m

Outlet 1 1/2"
Connect to water trap

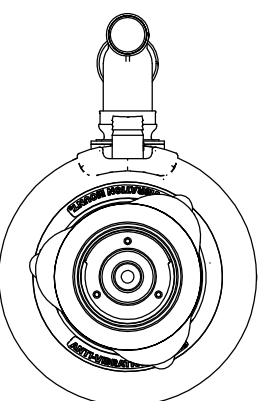

Top view

Voltage 230/1/50-60
Rated Power 0,55kW
Current 3,5A
Weight 11kg



TECHNICAL
SPECIFICATION

FOOD WASTE DISPOSER
DISPERATOR 400 BAS FOR SINK

Date: 2015.06.25

Dwg: 360202